

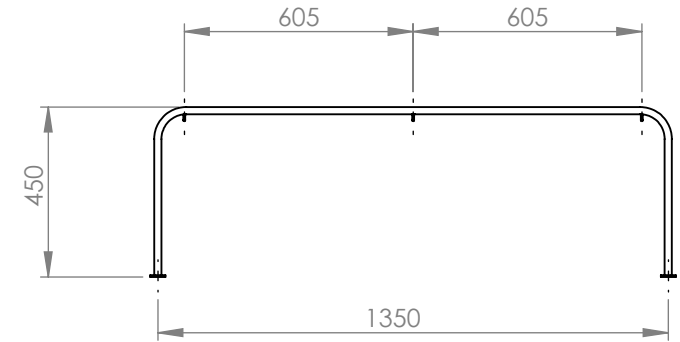

ITEM NO.	PART NUMBER	DESCRIPTION	QTY.
1	GM-TUB-BEN-01A	Tubular Bench Slat	12
2	GM-TUB-BEN-02B	Stand Alone Tubular Bench Foot	2
3	GM-TUB-BEN-01C	Tubular Bench Spacer	3

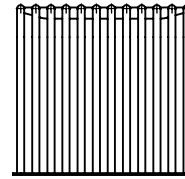
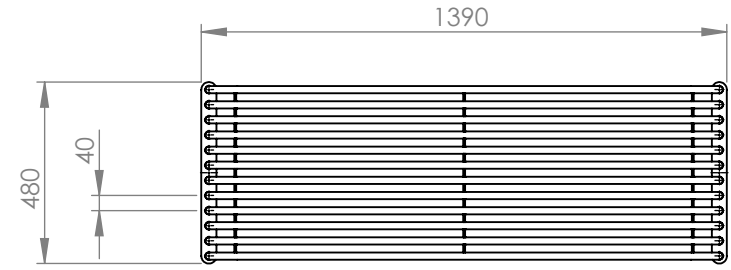
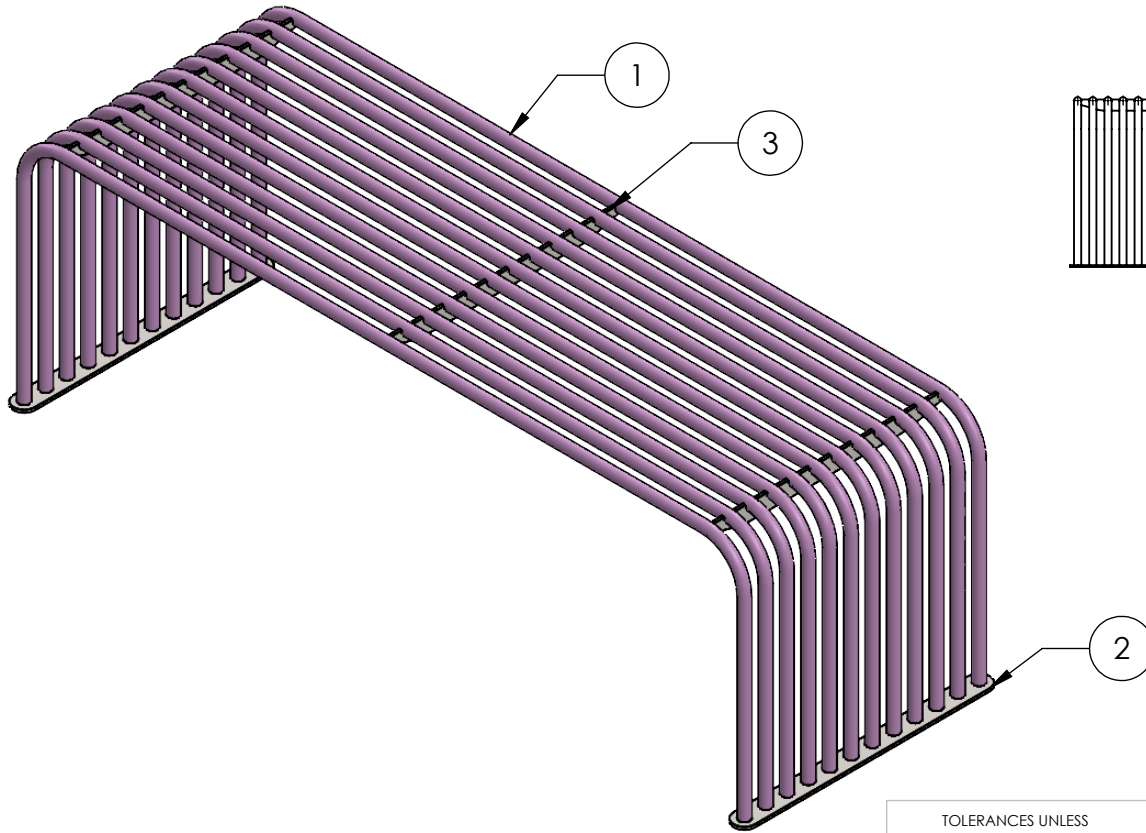

FULLY WELDED CONSTRUCTION

<p>TOLERANCES UNLESS OTHERWISE STATED.</p> <p>LINEAR:  0 - 250mm +/- 0.25mm  OVER 250mm +/- 0.5mm  ANGULAR: +/- 0.5deg</p>	 MATERIAL: See Parts	TITLE:	
		Stand Alone Tubular Bench Assy	
 Tel: 01422 359791 Web: shawmetal.co.uk	FINISH:	DWG/Part NO.	A4
	DRAWN Grant	SB-MAN-BEN-01	
DATE 1.3.23	SCALE 1:20	SHEET 1 OF	REVISION