

ITEM NO.	PART NUMBER	DESCRIPTION	QTY.
1	SB-MAN-TBL-01	Table Top Assembly	1
2	SB-MAN-HTBL-02	High Table Leg Assembly	2
3	SB-MAN-TBL-03	Table Glass	1

WEIGHT APPROX 44 KG

SCREW LEG ASSEMBLIES TO TOP ASSEMBLY USING  
12 OFF STAINLESS M5 X 20 C'SUNK SOCKET HEAD SCREWS

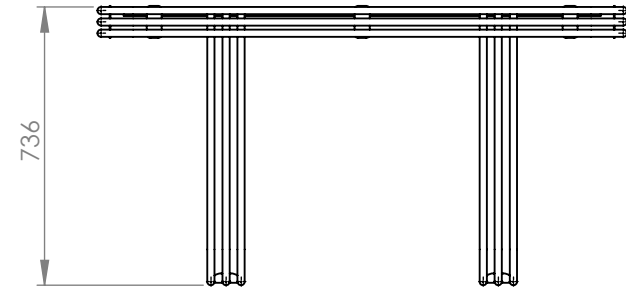
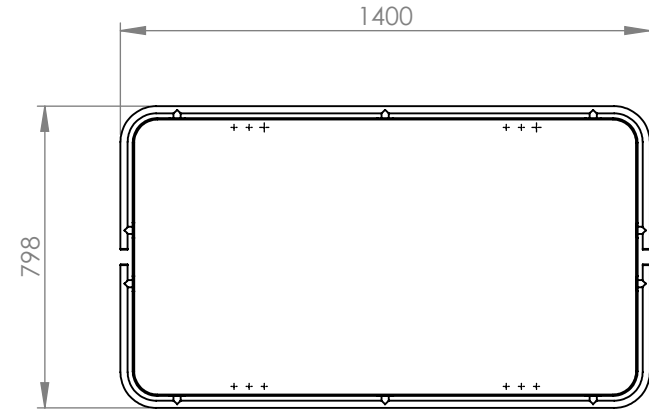
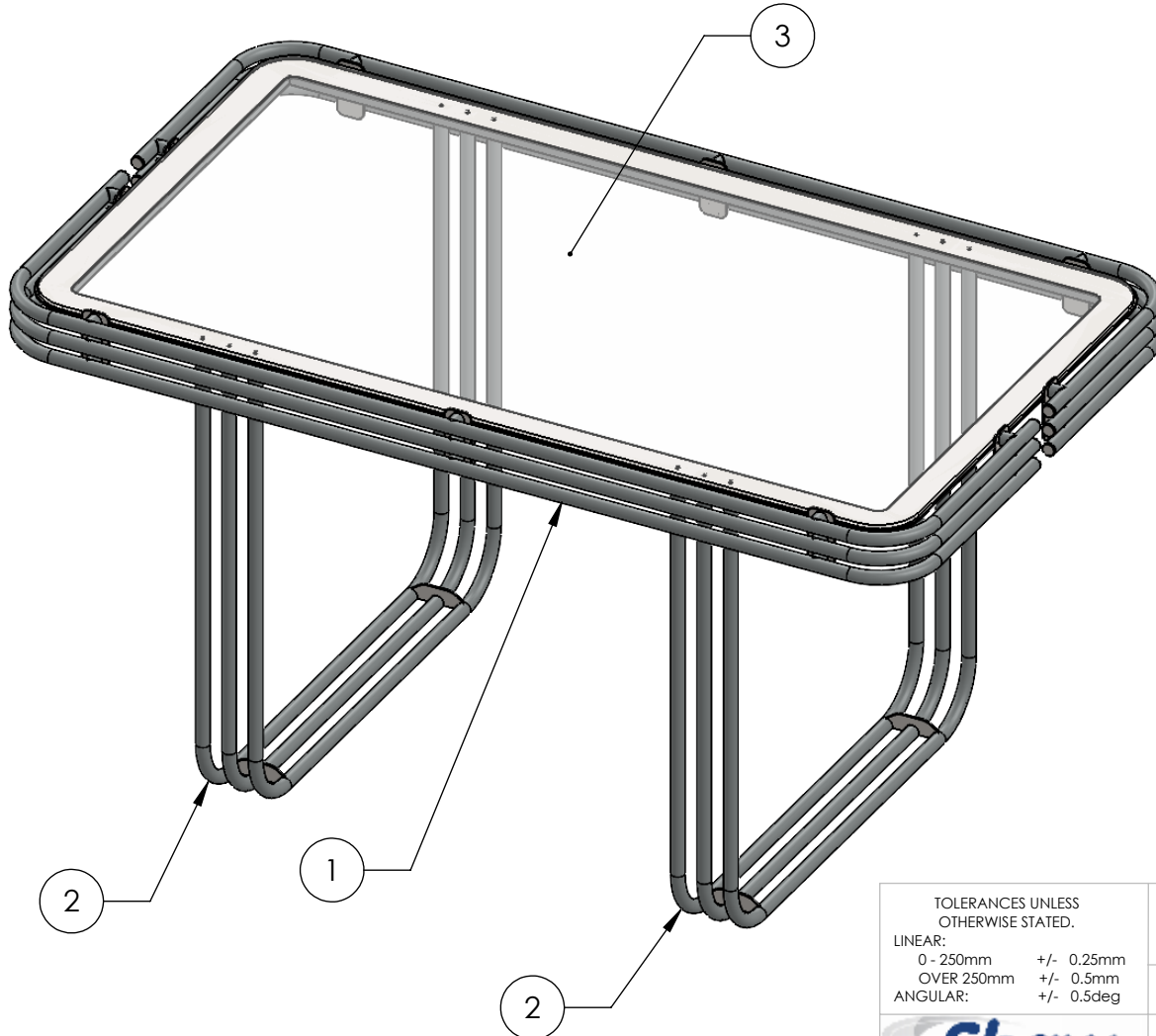

<p>TOLERANCES UNLESS OTHERWISE STATED.</p> <p>LINEAR: 0 - 250mm +/- 0.25mm OVER 250mm +/- 0.5mm ANGULAR: +/- 0.5deg</p>		TITLE:	
		High Table Assembly	
	MATERIAL:	DWG/Part NO.	
	See Parts	SB-MAN-HTBL	
FINISH:	Grant	SCALE	1:20
DRAWN	Grant	SHEET 1 OF	REVISION
DATE	04/05/2023	A4	
Tel: 01422 359791 Web: shawmetal.co.uk			