

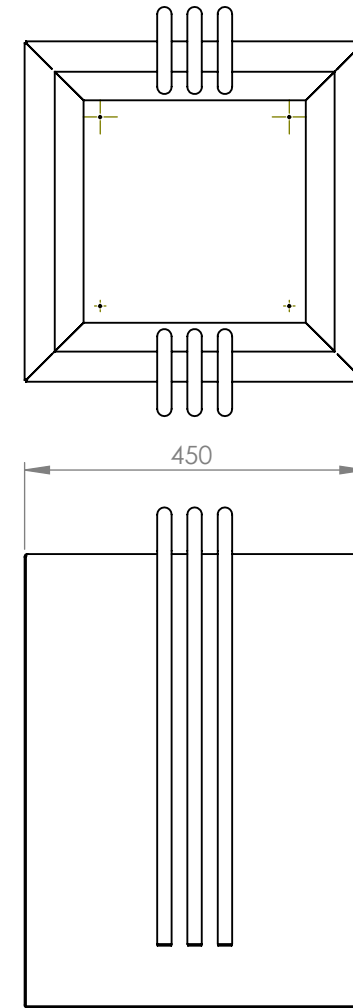

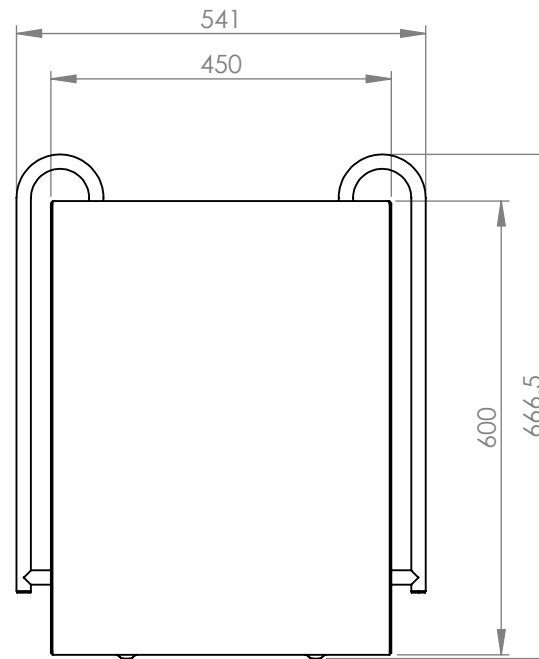

ITEM NO.	PART NUMBER	DESCRIPTION	QTY.
1	SB-MAN-PL-01	Planter Body Assembly	1
2	SB-MAN-PL-02	Planter Tube Assembly	6
3	SB-MAN-PL-03	Planter Spacer	6

FASTEN TUBE ASSEMBLIES TO BODY ASSEMBLY USING 6 OFF M5 X 10 STAINLESS SOCKET HEAD SCREWS AND 6 OFF M5 X 40 STAINLESS SOCKET HEAD SCREWS.

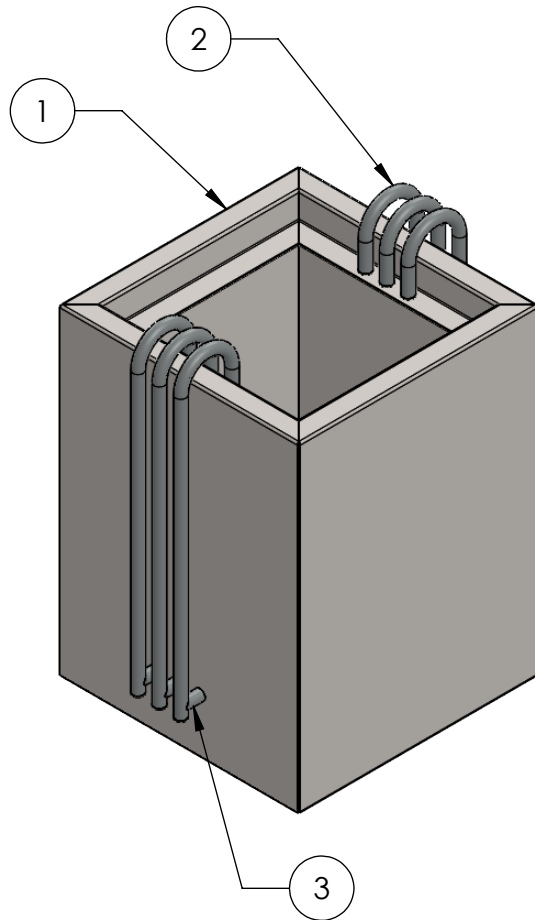

14.2.23 Design updated

TOLERANCES UNLESS OTHERWISE STATED. LINEAR: 0 - 250mm +/- 0.25mm OVER 250mm +/- 0.5mm ANGULAR: +/- 0.5deg	 	TITLE:	
	MATERIAL: See Parts	Planter Assembly	
	FINISH:	DWG/Part NO.	A4
	DRAWN Grant	SB-MAN-PL	
Tel: 01422 359791 Web: shawmetal.co.uk	DATE 14/02/23	SCALE 1:10	SHEET 1 OF REVISION