

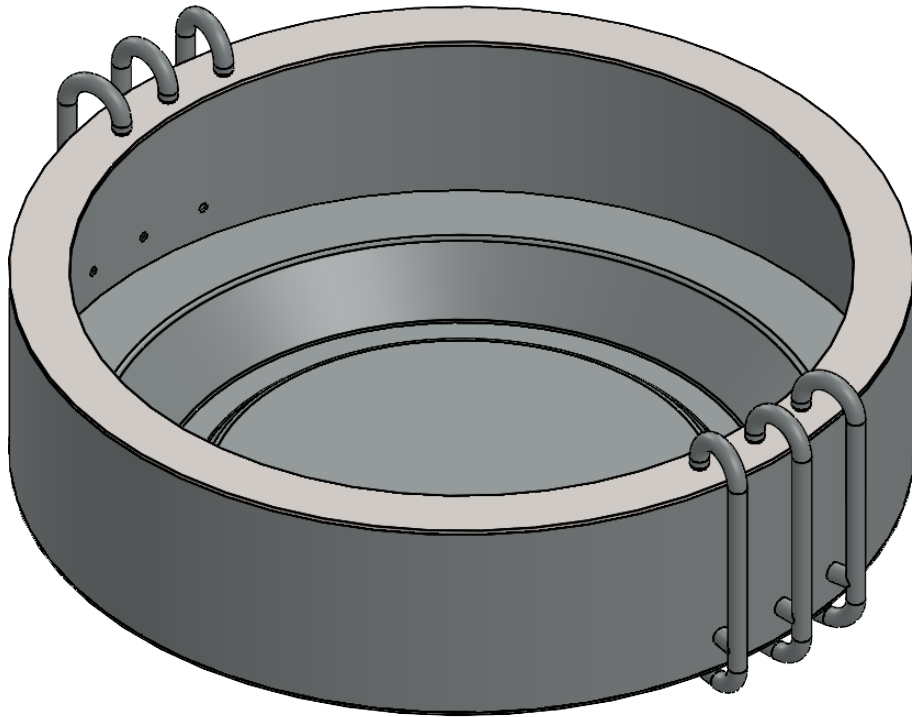

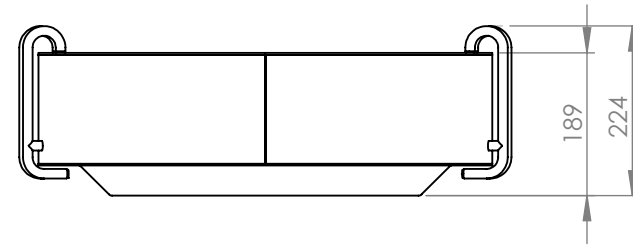
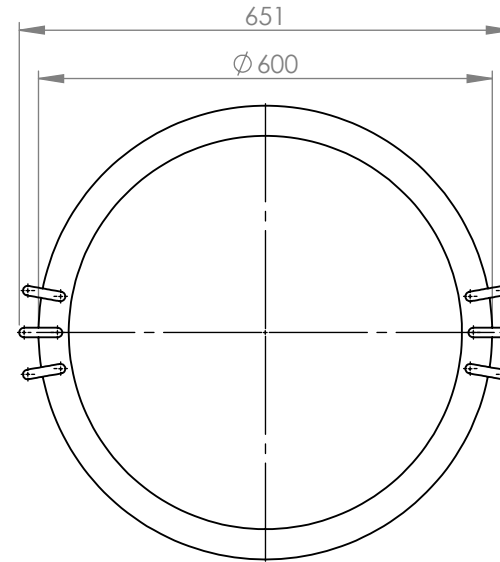

ITEM NO.	PART NUMBER	DESCRIPTION	QTY.
1	SB-FP6-01	Fire Pit 600 Body Assembly	1
2	SB-FP6-02	Fire Pit 600 Tube Assembly	6
3	SB-FP6-03	Spacer	6

WEIGHT APPROX 12 KG

PRELIMINARY DESIGN.
NOT FOR PRODUCTION.



<p>TOLERANCES UNLESS OTHERWISE STATED.</p> <p>LINEAR: 0 - 250mm +/- 0.25mm OVER 250mm +/- 0.5mm ANGULAR: +/- 0.5deg</p>	 	TITLE:	
	<p>MATERIAL: See Parts</p>	Fire Pit 600 Assembly	
	<p>FINISH:</p>	DWG/Part NO.	A4
<p>DRAWN Grant</p>	<p>DATE 04/01/2023</p>	SB-FP6	
<p>Tel: 01422 359791 Web: shawmetal.co.uk</p>	<p>SCALE 1:10</p>	<p>SHEET 1 OF</p>	<p>REVISION</p>