

ITEM NO.	PART NUMBER	DESCRIPTION	QTY.
1	SB-1SB-M2-01A	Front Main Tube	1
2	SB-1SB-M2-01B	Rear Main Tube	1
3	SB-1SB-M2-01C	Leg	4
4	SB-1SB-M2-01D	Foot	4
5	SB-1SB-M2-01E	Bench Seat Tube	15
6	SB-1SB-M2-01F	Tube Arm	4
7	SB-1SB-M2-01G	1 Seat Bench Comb	2

WEIGHT APPROX. 24 KG

ALL JOINS FULLY WELDED  
AND CLEANED OFF TO  
BE WATERTIGHT

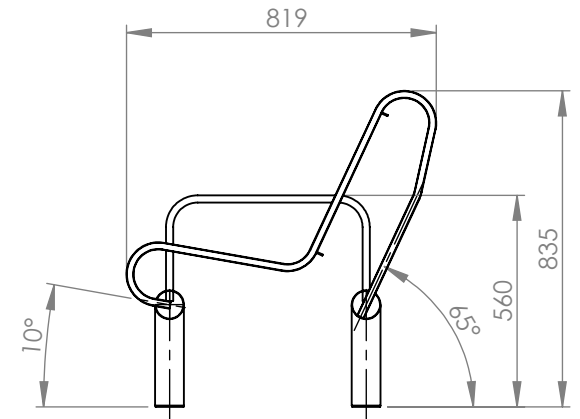
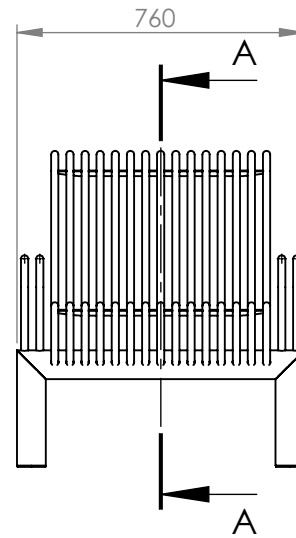
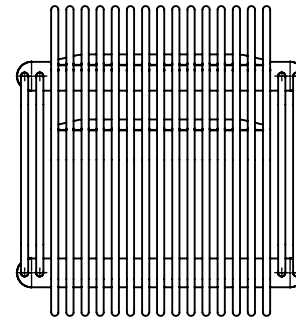
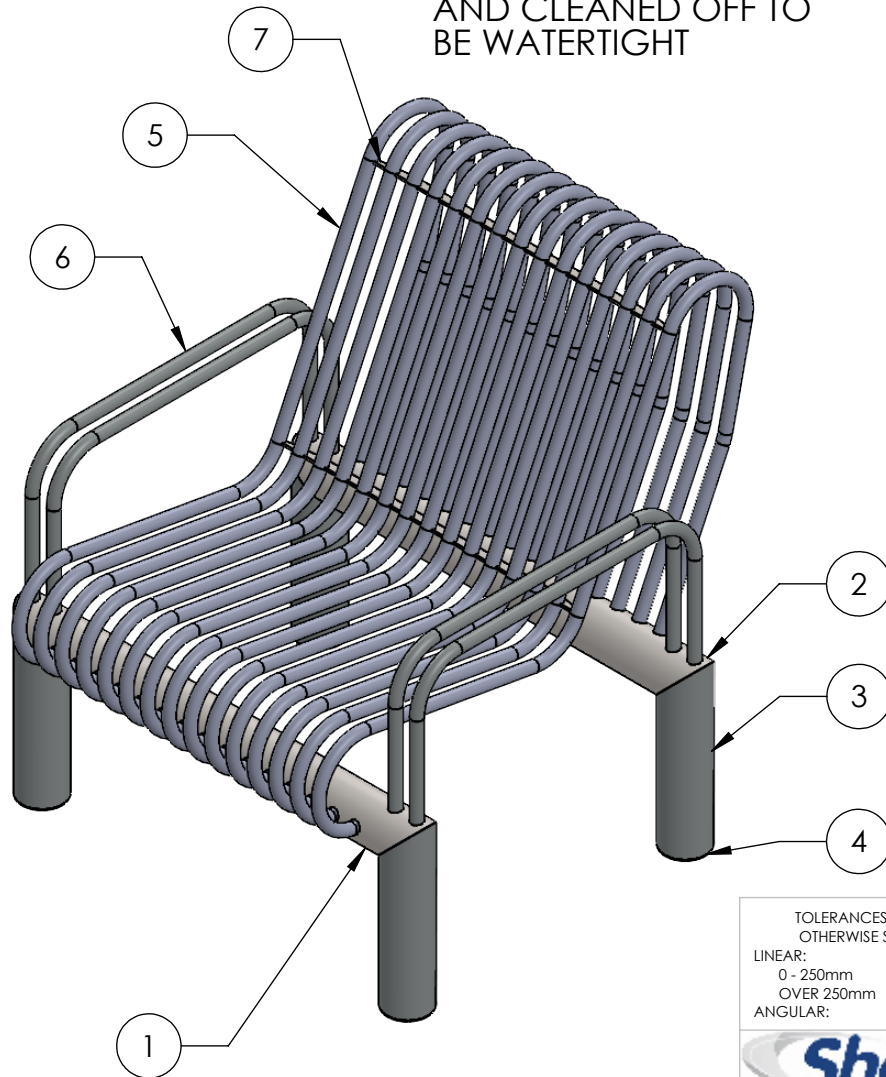

SECTION A-A

TOLERANCES UNLESS  
OTHERWISE STATED.  
LINEAR:  
0 - 250mm +/- 0.25mm  
OVER 250mm +/- 0.5mm  
ANGULAR: +/- 0.5deg



Tel: 01422 359791 Web: shawmetal.co.uk

MATERIAL:  
See Parts

FINISH:  
DRAWN  
Grant

DATE 04/10/2022

TITLE:  
1 Seat Bench Mk2 Assembly

DWG/Part NO.  
SB-1SB-M2-01

A4

SCALE 1:20 SHEET 1 OF REVISION